

Digital Signal Processing

Introduction

Areas of Applications - General

Areas of Applications - Mechanical Engineering

3 types of general problems addressed

Some typical signals and processing

DSP in various disciplines

Communication (Electronics, speech)

EE – home appliances (TV, Music)

Image processing

Control

Civil Engineering –Earthquakes, ground motions

Aeronautical Engineering

Medicine (EEG, ECG etc)

Physics (Optical devices)

Economics, Finance (Economic models, Stock market)

and many more

DSP in mechanical Engineering

Control

Measurements

Manufacturing

Diagnostics

Design (dynamic aspects)

Products (Mechatronics)

Vibration (noise) control

and many others

Black box model

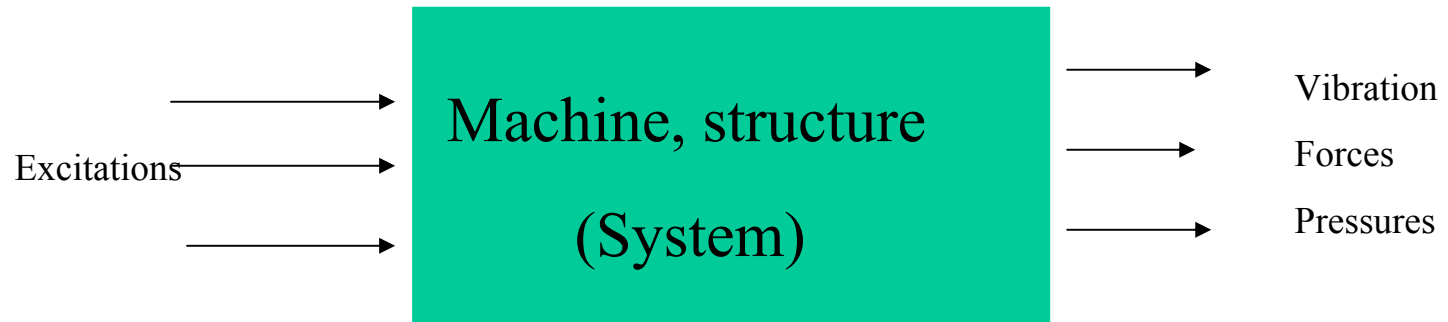

Surveillance

Machine, structure
(Not identified)

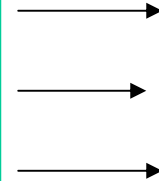

Vibration

Forces

Pressures

Example of application: Diagnostics

Identification

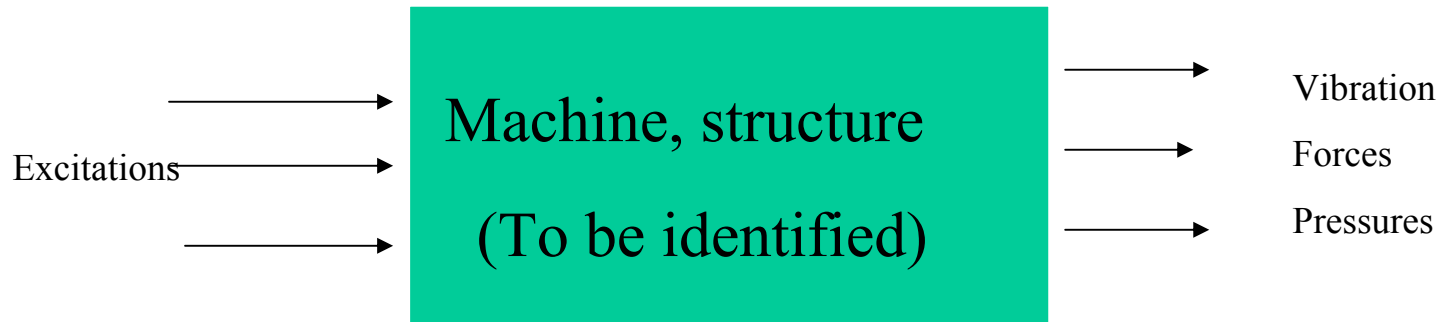

Example of application: Experimental Modal Analysis

Control of systems

Characterisation of excitations

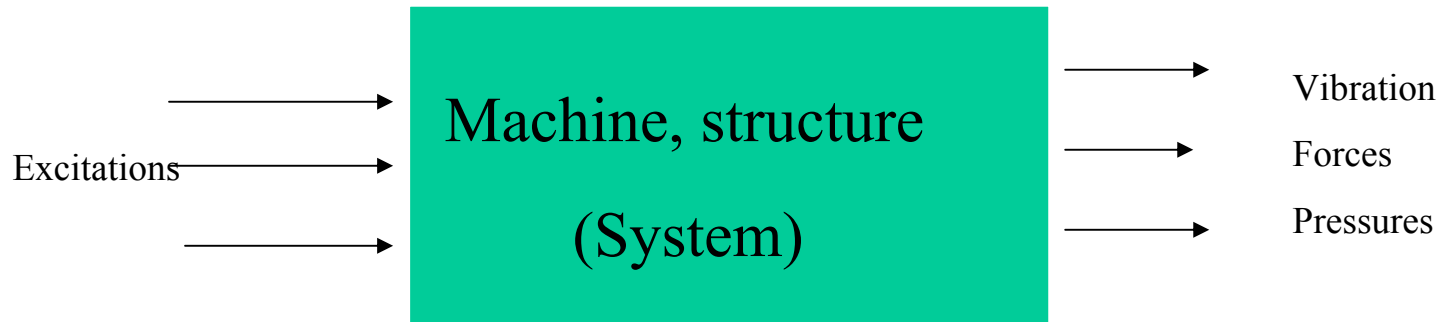

Example of applications: Exciting force estimation

Identification of acoustic sources

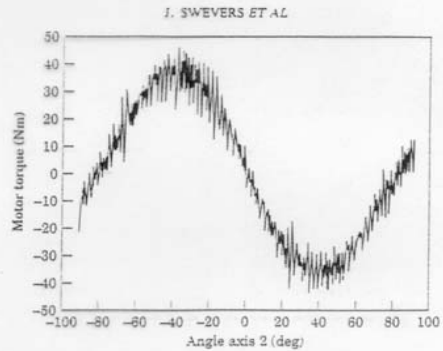

Figure 9. Measured motor torque for axis 2 as a function of the angular position of a

16

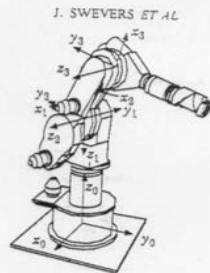

Figure 1. Schematic representation of a KUKA IR/361 industrial robot.

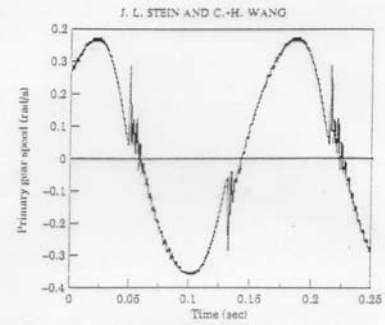

Figure 5. A typical raw primary speed signal with bounces indicating tooth impact.

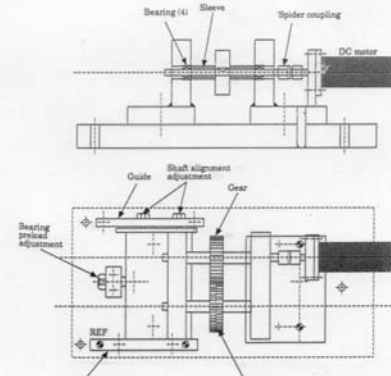

Figure 1. Servomechanism test stand.



Analysis of Vibrations



Diagnostics of Machinery : Frequency analysis

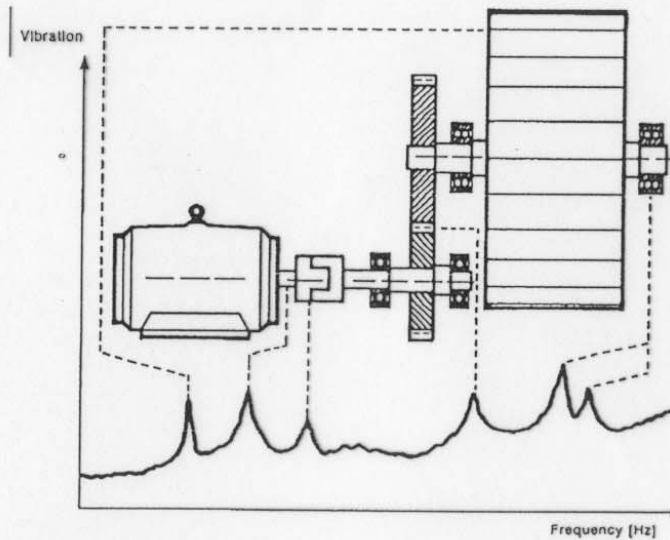

Faculty of Mechanical Engineering

The Co-operative Marketing Programme (CMP)

Selecting the right software is vital for a successful and secure computer solution. The CMP helps you to choose with confidence.

The CMP brings you a choice of top applications from market leaders in our specialist areas. They are thoroughly vetted by Digital for quality support of Digital architecture, integration capabilities and conformance to industry standards.

Each third party supplier has a superb customer satisfaction record and proven long-term support ability. All have first-class working relationships with Digital. Joint consultations with customers, demonstrations and promotions are essential to the CMP. Together, we work towards optimum application performance, with commitments on new product development and support of new digital technology.

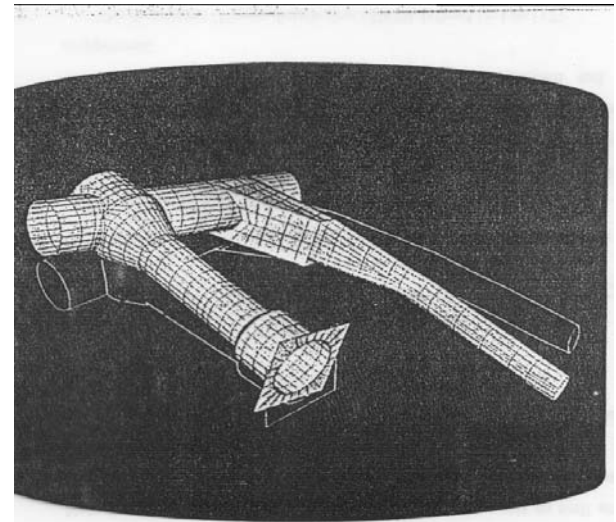
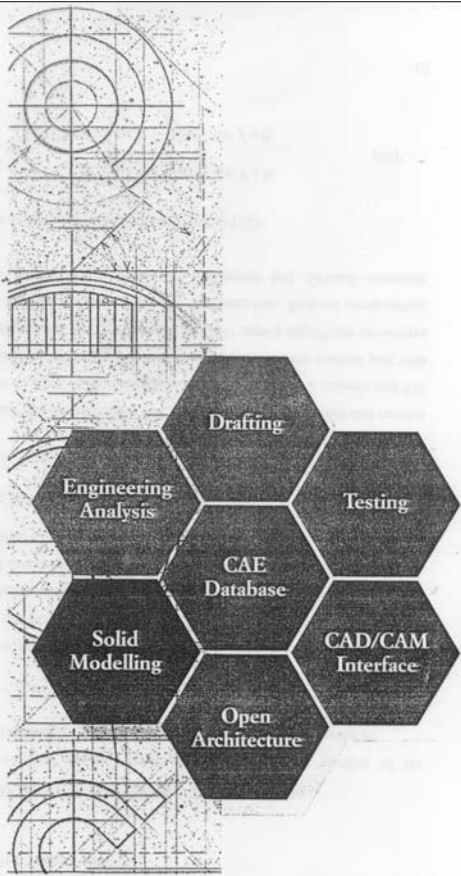

Deformed geometry, presented in either static or animated form, lets you see clearly how a structure will move under load.

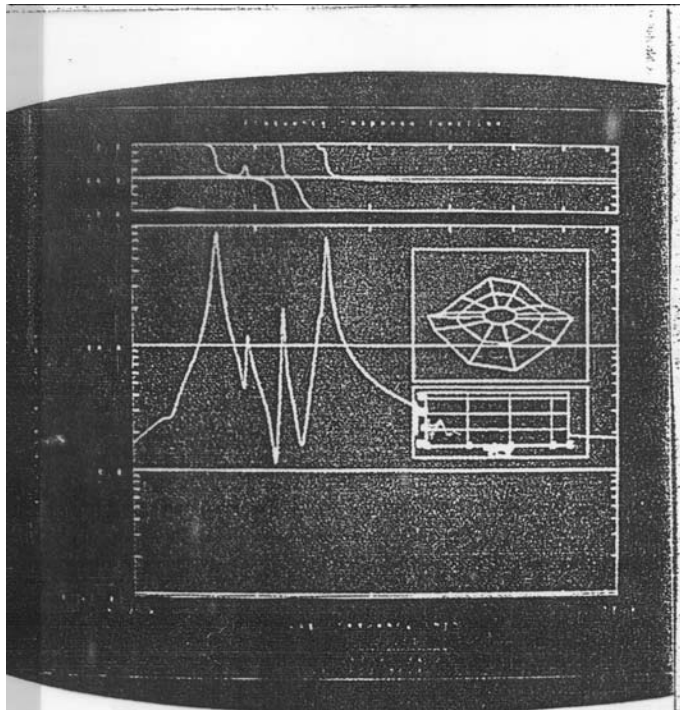

Geometric data and an impulse response functions are inset on a frequency response function plot.

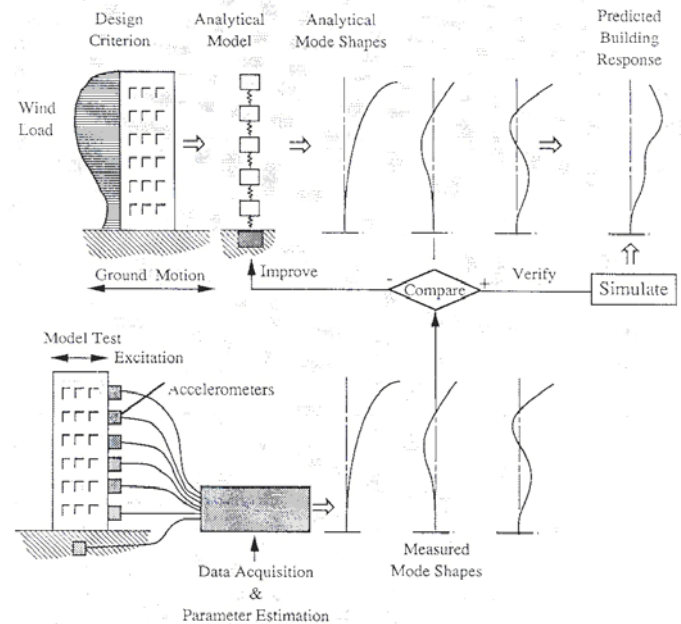

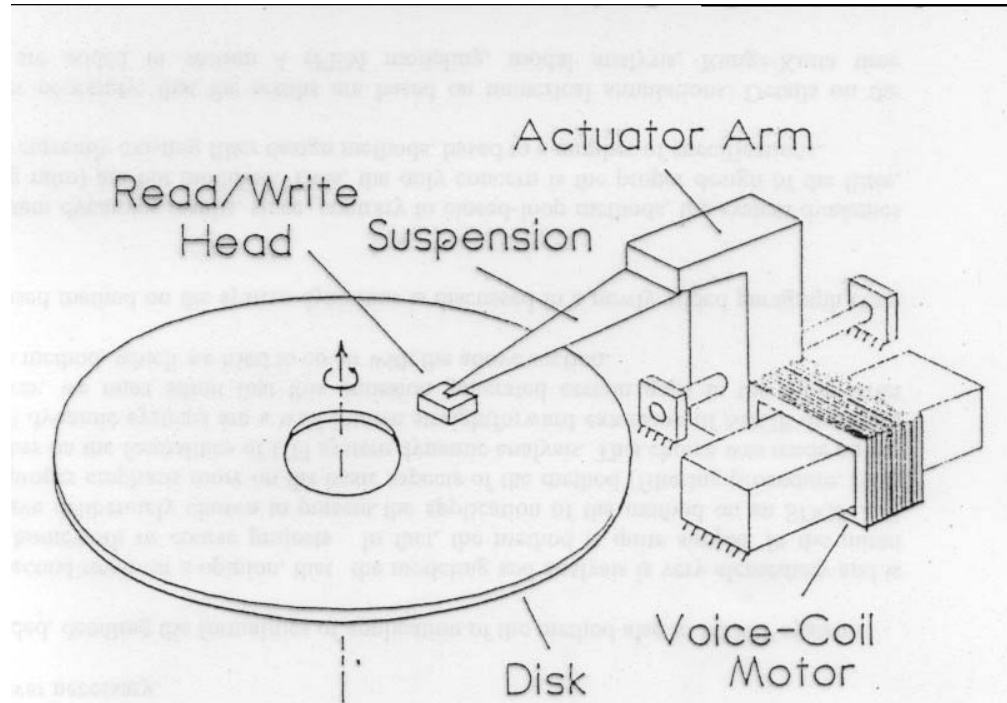

Fig. 1 Relevant mechanical components of small form factor rigid disk drives

JANUARY 1990, Vol. 112 / 33

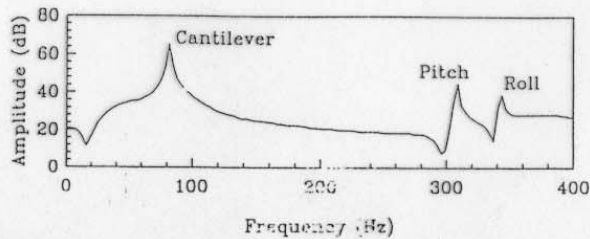

Fig. 6 Frequency spectrum of transient response of head/suspension in free head vibration test.

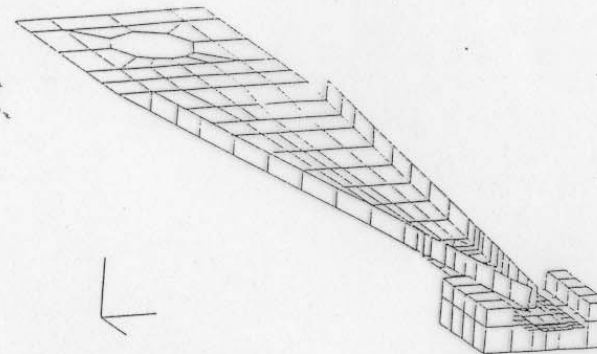

Fig. 8 Finite element model of read/write head suspension

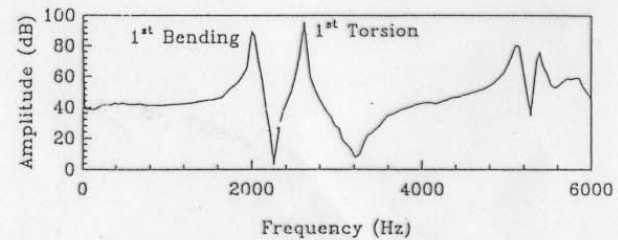
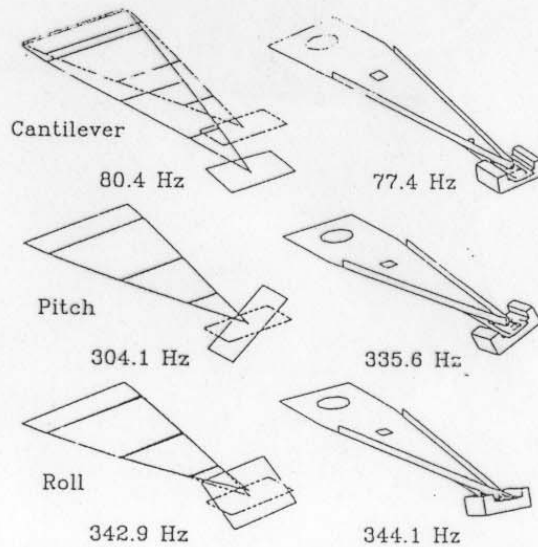
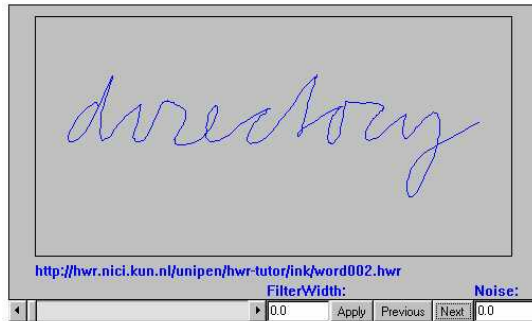

Fig. 9 Transfer function of suspension with regular head (fixed head vibration test)

Also in Fig. 7, results from the finite element analysis (FEA) are shown for comparison. Figure 8 shows the complete finite element model which consists of 419 nodes and 310 elements. Although the primary focus of the current work is on experimentation, numerical analysis is an important and integral

An interactive demo of low-pass filtering of on-line h



An interactive demo of low-pass filtering of on-line hand

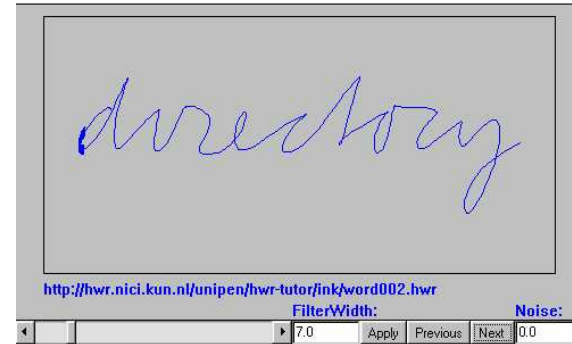

[Source code](#)

An interactive demo of low-pass filtering of on-line hand

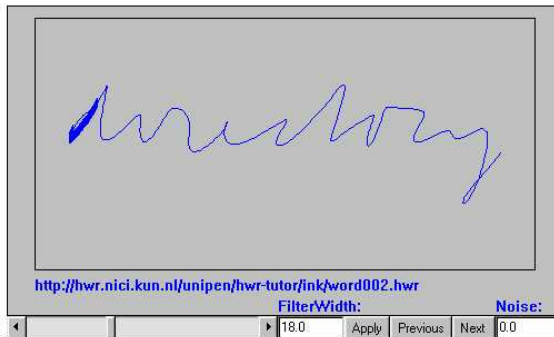

[Source code](#)

An interactive demo of low-pass filtering of on-line l

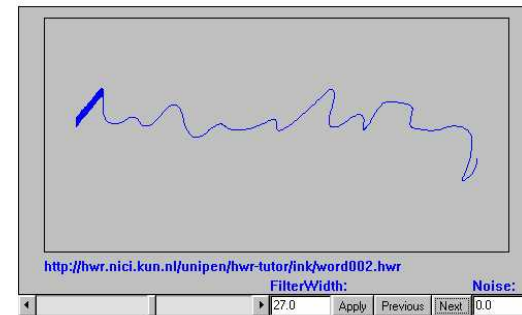

[Source code](#)